

XCTB - Current transformers for power quality applications up to 20 kHz

High-precision harmonic measurements up to 20 kHz

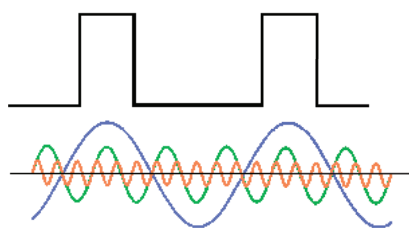

www.mbs-ag.com



9 kHz



ZERTIFIKAT ■ CERTIFICATE ■ CERTIFICADO ■ CERTIFICAT ■ 證書 ■ CERTIFICATE ■ ZERTIFIKAT



Management Service

CERTIFICATE

The Certification Body
of TÜV SÜD Management Service GmbH

certifies that



MBS AG
Eisbachstraße 51
74429 Sulzbach-Laufen
Laufen
Germany

has established and applies
a Quality Management System for

**Development, production and distribution of
measuring transducers, energy meters, low voltage current transformers,
split core current transformers, all current sensors, bus bar isolators /
supports, switchgear cabinet heating and control equipment,
"State approved test organization for measurement and calibration
of current transformers and energy meters".**

An audit was performed, Report No. **70003062**.

Proof has been furnished that the requirements
according to

ISO 9001:2015

are fulfilled.

The certificate is valid from **2018-03-15** until **2021-03-14**.

Certificate Registration No.: **12 100 20346 TMS**.

Product Compliance Management
Munich, 2018-02-22



MS/01-07/2014

TÜV SÜD Management Service GmbH • Zertifizierungsstelle • Ridlerstraße 65 • 80339 München • Germany
www.tuev-sued.de/certificate-validity-check

TUV®

MBS AG

Eisbachstraße 51 · 74429 Sulzbach-Laufen
Germany

Telefon: +49 7976 9851-0 · Telefax: +49 7976 9851-90
E-Mail: info@mbs-ag.com · Web: www.mbs-ag.com

New measuring requirements for inductive current transformers in the low-voltage range

Changes to the structure of generation and consumption

Over the last few years, the proportion of renewable energy in Germany has grown massively. Wind, biomass, photovoltaic and hydroelectric plants now make up approximately 30% of the country's energy mix.

Unlike in conventional nuclear or coal-fired power stations, where all synchronous generators are used to produce electricity, here inverters or frequency converters are used. As such, it is not always possible to achieve a clean sine wave.

The distortions are caused by the switching semiconductor elements in the inverter. Harmonics generated in this way are whole multiples of the first harmonic and can extend far into the single-digit kilohertz range. The total harmonic distortion (THD) factor¹ specifies the undesirable distortion ratio of the 50 Hz sinusoidal oscillation and regularly reaches between 10 and 30%.

In addition to the harmonics produced by inverters on the generator side, there have also been changes on the consumer side in recent years. Non-linear consumers such as LED or energy-saving lamps are pushing linear ones, like traditional incandescent bulbs, out of our daily lives almost completely.

Plug-in power supply units for mobile phones and laptops are no longer made from small transformers either, but from semiconductor circuits known as switched-mode power supplies. It would not be possible to create such small, light power supply units any other way. But these benefits are set against one big disadvantage: the current is drawn from the public grid not as a sinusoidal waveform, but in pulses. The figure below illustrates this:

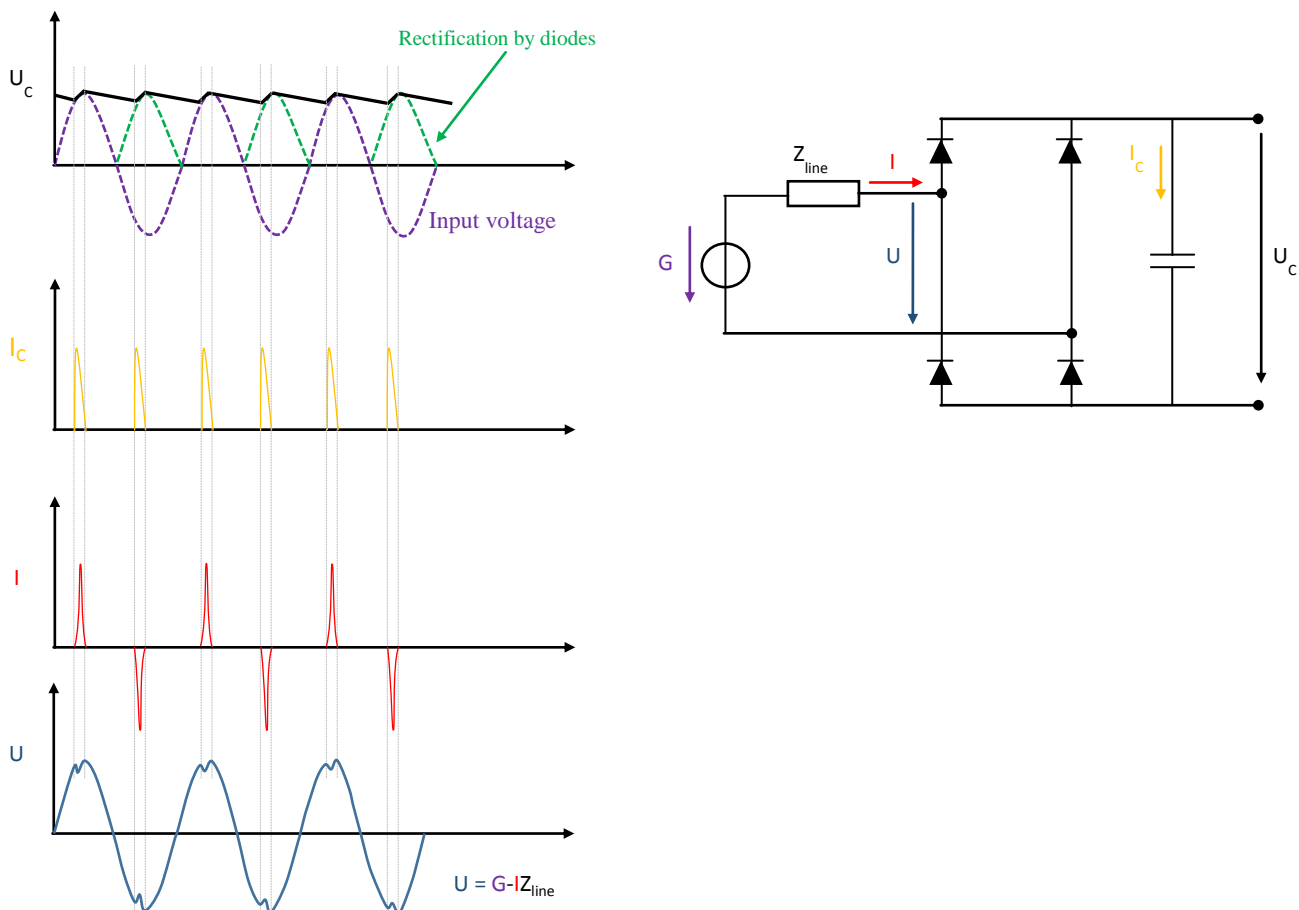

Figure 1: Bridge rectifier with pulsed current draw

The filter capacitor shown in the diagram not only smooths the required output voltage, it is also recharged in pulses by the rectifier diodes. These steep current peaks generate reactive power on the one hand, and harmonics on the other.

¹ The THD is the ratio of the harmonic component to the first harmonic

Standards regulate limit values – but not always!

There is already a corresponding set of international norms that limits harmonic currents in end devices with a power consumption > 75 W. Devices under 75 W are not currently covered by standards. In the interests of keeping costs down, manufacturers do not usually implement filter measures or complex power factor correction. The EN 61000-3-2 set of standards does not come into play until the 25 W mark for lamps either; for example, where energy-saving lamps are concerned, THD_i values of 30 to 70% and higher are not uncommon during warm-up and in continuous duty. It should also be noted that, even when they do kick in, the standards only define limit values up to 2 kHz. As a result, manufacturers have hardly taken interference suppression into account at all when developing electronic products for the frequency range > 2 kHz in the past.

In addition, more and more electrical motors with variable-frequency drive technology are being used in the industrial sector. Today already, the percentage of electrical motors sold that have a frequency-controlled drive stands at around 40%. The majority of these motors utilise pulse width modulation technology, which can generate THD_i values in the range from 100 to 120%. Clean sine waves are almost impossible to identify at these values.

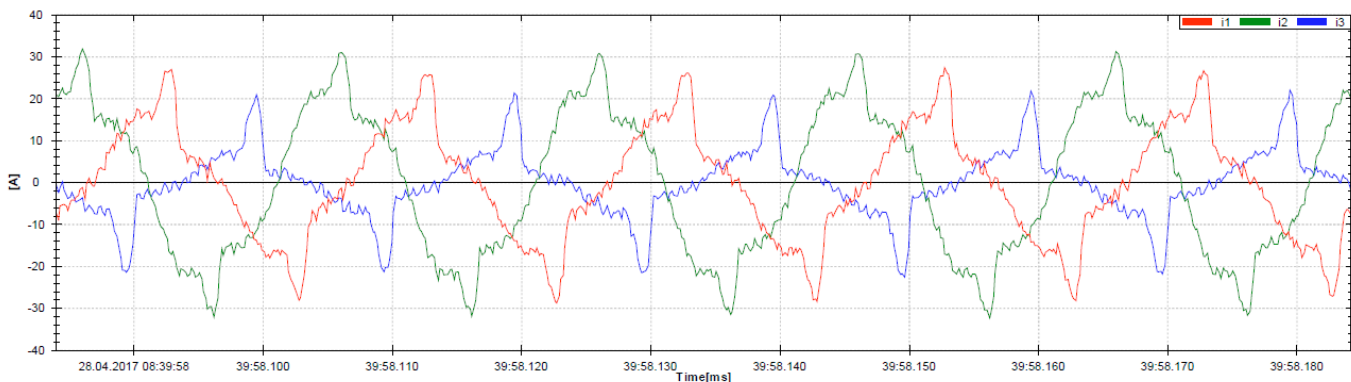

Figure 2: Flow of current for an industrial customer on the low-voltage grid

Power electronics have so many benefits that we can categorically state there will be no return to linear consumers such as the traditional incandescent bulb. In fact, we can expect harmonic loads to increase even further in European grids, due to the development of alternative sources of energy and the growth of non-linear consumers. We should also bear in mind that having lots of consumers that are not regulated by standards could cause considerable interference overall. Filter systems have already had to be installed in office buildings where just computers, telephone systems and energy-efficient bulbs are used, in order to bring problems with harmonics under control.

Effects of harmonics

Grid operators are primarily interested in the economic effects of harmonics. When it comes to harmonic **currents**, the most important phenomena are as follows²:

- Overloading of neutral conductors
- Overheating of transformers
- False tripping of circuit breakers/miniature circuit breakers
- Overstressing of power-factor correction capacitors
- Skin effects

If the distortion level in the supply **voltage** reaches a value > 10%, this shortens the lifetime of devices considerably. This reduction is estimated as follows:

- 32.5% for 1-phase machines
- 18% for 3-phase machines
- 5% for transformers.

To maintain the lifetime expected from the nominal load, the devices named above must be over-dimensioned.

² Schneider Electric Wiki (accessed 09/01/2018) http://de.electrical-installation.org/dewiki/Wirtschaftliche_Auswirkungen#St.C3.B6rungsausl.C3.B6sung_und_Anlagenausfall

Standard regulation for distribution network operators

The latest draft of VDE-AR-N 4100¹ deals with this matter. Point 5.4.4.3 of this regulation refers to harmonic currents of up to **9 kHz** that need to be monitored and covers not only **generating plants**, but also **receiving plants** and **storage systems**. The customer should liaise with the grid operator and take action to reduce harmonic currents – particularly by constructing filter circuits. In future we can assume, therefore, that current measurements up to 9 kHz will be taken continuously across the whole low-voltage network.

Looking at the overall picture of the rise in distributed energy generation plants and non-linear consumers, we can see this is a very sensible move. Grid operators and their customers will need measuring equipment that can accurately record harmonic currents of up to 9 kHz.

Current transformers up to 20 kHz

MBS AG offers the full series of XCTB current transformers for measurements up to 20 kHz. These products guarantee high-precision transmission up to 20 kHz on the one hand, and are designed to withstand the thermal demands of running in networks subject to harmonics on the other.

Output signals are 1 or 5 A, just like with the familiar inductive current transformer to IEC 61869-2. Performance data corresponds to standard values too. As a result, these transformers can also be used in conventional 50 Hz applications. An additional rating plate defines the frequency transmission behaviour.

Burden 0.2VA – Sr pf1
$\varepsilon \leq 2\% \mid \Delta\phi \leq 2^\circ$ 0,05-10 kHz
$\varepsilon \leq 3\% \mid \Delta\phi \leq 3^\circ$ 10-20 kHz
Connection cable: HELUKABEL
Type: OZ-500 HMH-C 2x2.5 or 2x4 mm ² (0-10 m)

Figure 4: Frequency transmission behaviour

Since the connecting cable affects the load and the transmission behaviour more if it is long, we recommend the OZ-500 HMH-C cable from Helukabel GmbH (2 x 2.5 mm² or 2 x 4 mm² version) for harmonic measurements up to 20 kHz. MBS AG carries out its accuracy tests using this type of cable too. The customer can now benefit from a consistent measuring chain and reliable measured values in the frequency range up to 20 kHz.

What's more, the XCTB series offers improved insulation resistance to voltage peaks and can also be used for operating voltages up to 1000 V in accordance with an insulation rating of 1.2 / 6 / – kV.

¹ TAR low voltage (E VDE-AR-N 4100): draft published 28/04/2017

Typical frequency responses of the XCTB with resistive load

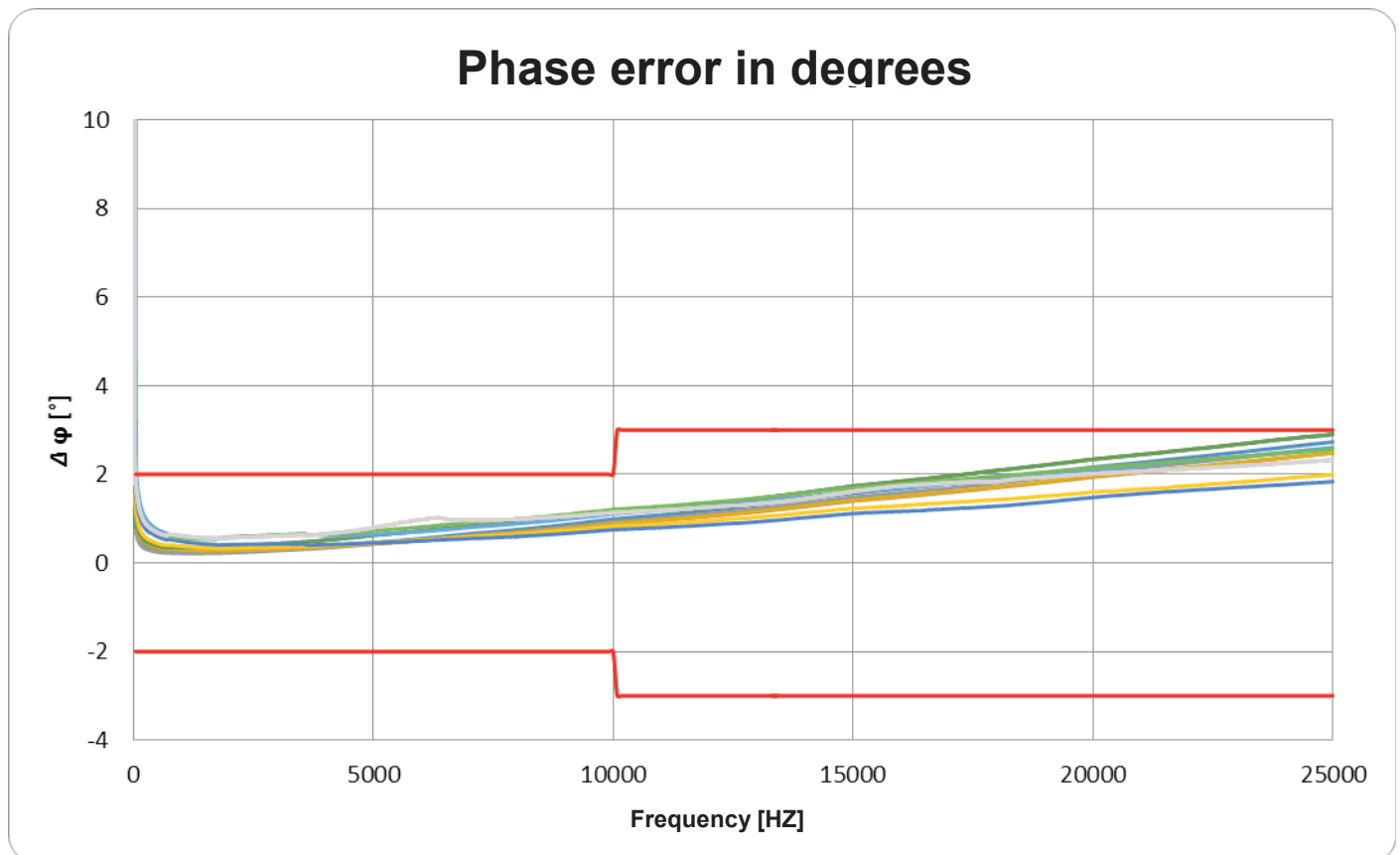
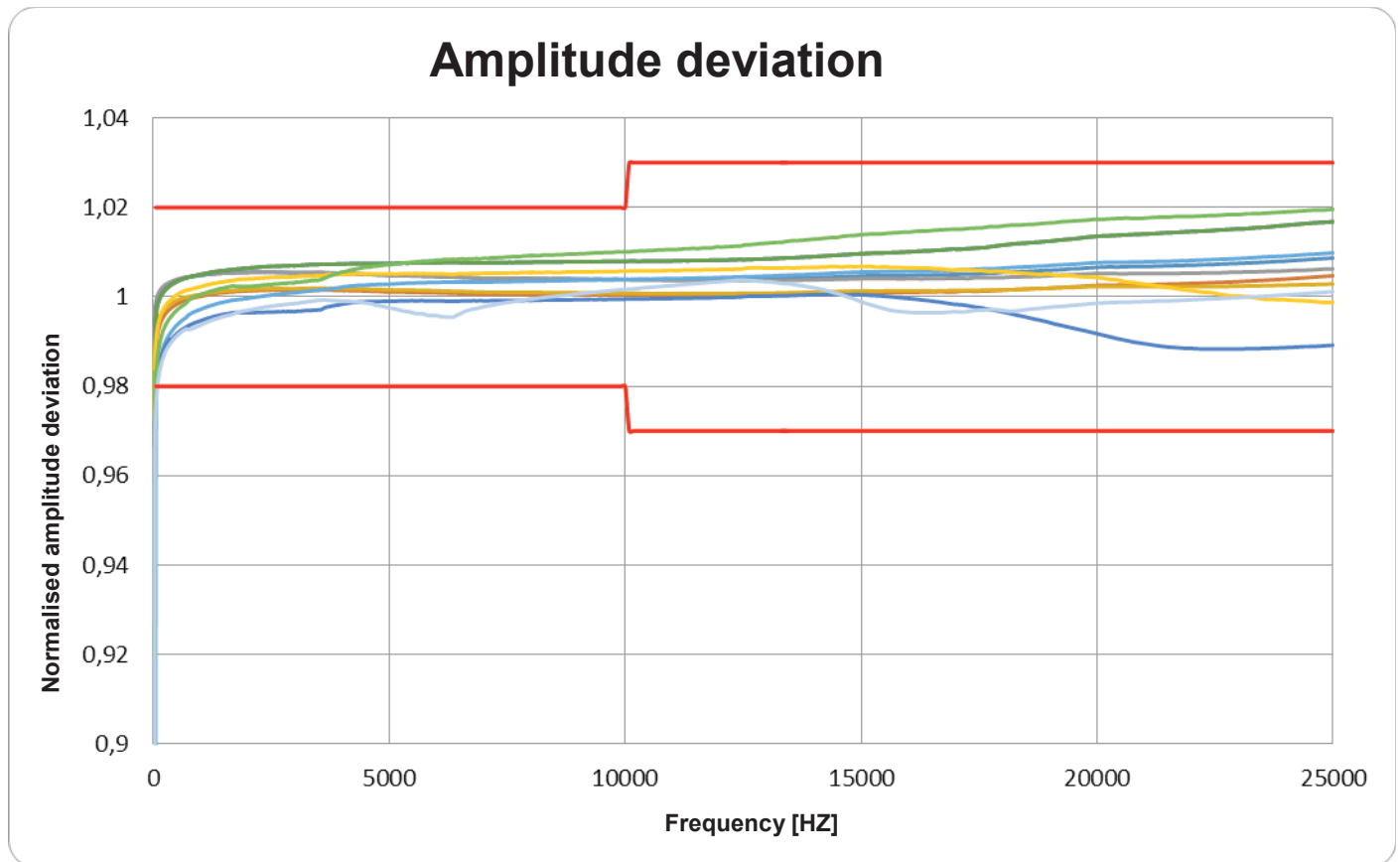

Plug-in current transformers with screwless “Cage Clamp®” connection system, for power quality applications up to 20 kHz

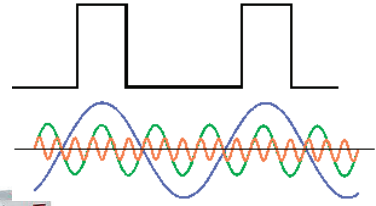

Screwless connection system thanks to “Cage Clamp®” spring-type terminal (front or top)

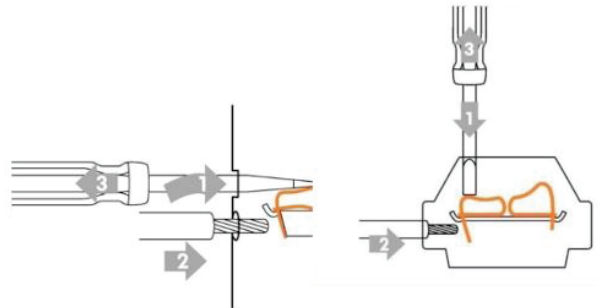

Further information:

- Innovative, time-saving connection option (front or top) for solid and flexible conductors, max. 4 mm² – no need for ferrule terminals
- Resistant to shock and vibration
- Maintenance-free, gas-tight connection
- High current-carrying capacity and high mechanical retention forces
- Low-voltage current transformers for max. operating voltages U_m up to 1.2 kV, can be used in 690 V networks
- Insulation test voltage: 6 kV, U_{rms} , 50 Hz, 1 min
- **Higher insulation level 1.2/6/12 kV – tested lightning impulse voltage for 690 V systems acc. to IEC 61439-1 and -2**
- Available in nominal current ranges 50...2000 A
- Accuracy classes @ 50 Hz: 1; 0.5; 0.5S, 0.2 and 0.2S
- **Connecting cable for harmonic measurements: HELUKABEL type: OZ-500 HMH-C with 2x2.5 or 2x4 mm² (0–10 m)**
- Harmonic measurements with load 0.2 VA – Sr pf1 (power factor 1)
- Measuring accuracy up to 20 kHz: $\epsilon \leq 2\% \mid \Delta\phi \leq 2^\circ @ 0.05\text{--}10 \text{ kHz} \parallel \epsilon \leq 3\% \mid \Delta\phi \leq 3^\circ @ 10\text{--}20 \text{ kHz}$
- Can be continuously overloaded with 120% of the primary nominal voltage
- Suitable for networks subject to harmonics with fundamental frequencies of 50 Hz or 60 Hz
- Insulation class: E
- Working temperature range: $-5^\circ\text{C} < T < +50^\circ\text{C}$
- Storage temperature range: $-25^\circ\text{C} < T < +70^\circ\text{C}$
- Unbreakable plastic housing made of polycarbonate, self-extinguishing, flame resistant
- Packing unit: 1 piece
- Customs tariff number: 85043129

XCTB 31.35

Plug-in current transformers

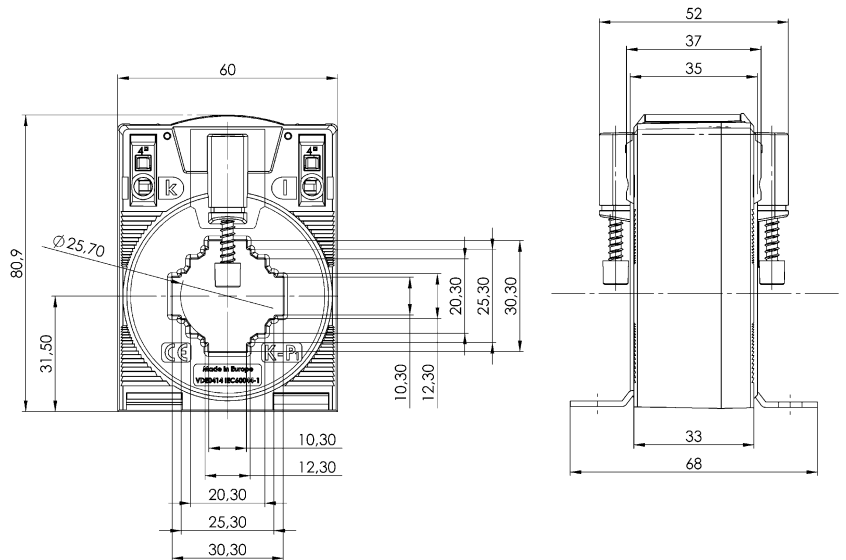

Dimensions:

- Bus bar 1: 30 x 10 mm
- Bus bar 2: 25 x 12 mm
- Bus bar 3: 20 x 20 mm
- Circular conductor: 25.7 mm
- Installation width: 60 mm
- Installation height: 80.9 mm
- Overall installation depth: 52 mm

Technical data:

- Therm. nominal continuous current I_{cth} : $1.2 \times I_N$
- Therm. nominal short-time current I_{th} : $60 \times I_N$, 1 s
- Max. operating voltage U_m : 1.2 kV, U_{rms}
- Insulation test voltage: 6 kV, U_{rms} , 50 Hz, 1 min
- Lightning impulse voltage: 12 kV, 1.2/50 μ s**
- Nominal frequency: 50/60 Hz
- Technical standards applied: DIN EN 61869, Part 1 + 2
- Harmonic measurements with load 0.2 VA – Sr pf1
- Measuring accuracy up to 20 kHz: $\epsilon \leq 2\% \mid \Delta\phi \leq 2^\circ @ 0.05\text{--}10 \text{ kHz}$
 $\epsilon \leq 3\% \mid \Delta\phi \leq 3^\circ @ 10\text{--}20 \text{ kHz}$

Ordering table for XCTB 31.35 with secondary current 5 A

Secondary current		5 A				
Primary current [A]	Rated power [VA]	Accuracy class				
		1	0.5	0.5S	0.2	0.2S
		Order no.	Order no.	Order no.	Order no.	Order no.
60	1.25	51-0001				
75	2.5	51-0002				
80	2.5	51-0003				
100	1.5		51-0014	51-0033	51-0052	
	2.5	51-0004	51-0015	51-0034		
125	1		51-0016	51-0035	51-0053	51-0067
	1.5		51-0017	51-0036	51-0054	51-0068
	2.5	51-0005	51-0018	51-0037		
150	1.5		51-0019	51-0038	51-0055	51-0069
	2.5		51-0020	51-0039		
	5	51-0006				
200	1.5		51-0021	51-0040	51-0056	
	2.5		51-0022	51-0041	51-0057	
	5	51-0007	51-0023	51-0042	51-0070	
250	2.5		51-0024	51-0043	51-0058	51-0071
	5		51-0025	51-0044	51-0059	51-0008
300	2.5		51-0026	51-0045	51-0060	51-0072
	5	51-0009	51-0027	51-0046	51-0061	51-0073
400	5	51-0010	51-0028	51-0047	51-0062	51-0074
	2.5		51-0029	51-0048	51-0063	51-0075
500	5	51-0011	51-0030	51-0049	51-0064	51-0076
	2.5		51-0031	51-0050	51-0065	51-0077
600	5	51-0012	51-0032	51-0051	51-0066	51-0078

Ordering table for XCTB 31.35 with secondary current 1 A

Secondary current		1 A				
Primary current [A]	Rated power [VA]	Accuracy class				
		1	0.5	0.5S	0.2	0.2S
		Order no.	Order no.	Order no.	Order no.	Order no.
50	0.5	51-2001				
60	1.25	51-2002				
75	2.5	51-2003				
80	2.5	51-2004				
100	1.5		51-2015	51-2034	51-2053	
	2.5	51-2005	51-2016	51-2035		
125	1		51-2017	51-2036	51-2054	
	1.5		51-2018	51-2037	51-2055	51-2067
	2.5	51-2006	51-2019	51-2038		
150	1.5		51-2020	51-2039	51-2056	51-2068
	2.5		51-2021	51-2040		
	5	51-2007				
200	1.5		51-2022	51-2041	51-2057	51-2069
	2.5		51-2023	51-2042	51-2058	51-2070
	5	51-2008	51-2024	51-2043		
250	2.5		51-2025	51-2044	51-2059	
	5	51-2009	51-2026	51-2045	51-2071	
300	2.5		51-2027	51-2046	51-2060	51-2072
	5	51-2010	51-2028	51-2047	51-2061	
400	5	51-2011	51-2029	51-2048	51-2062	51-2073
500	2.5		51-2030	51-2049	51-2063	51-2074
	5	51-2012	51-2031	51-2050	51-2064	
600	5	51-2013	51-2032	51-2051	51-2065	51-2075
750	5	51-2014	51-2033	51-2052	51-2066	51-2076

Accessories

Quick-fix (order no.: 55021)



Cover sealing (order no.: 59057)



Snap-on mount for installing the transformer on a 35 mm DIN rail (order no.: 55015)



XCTB 41.35

Plug-in current transformers

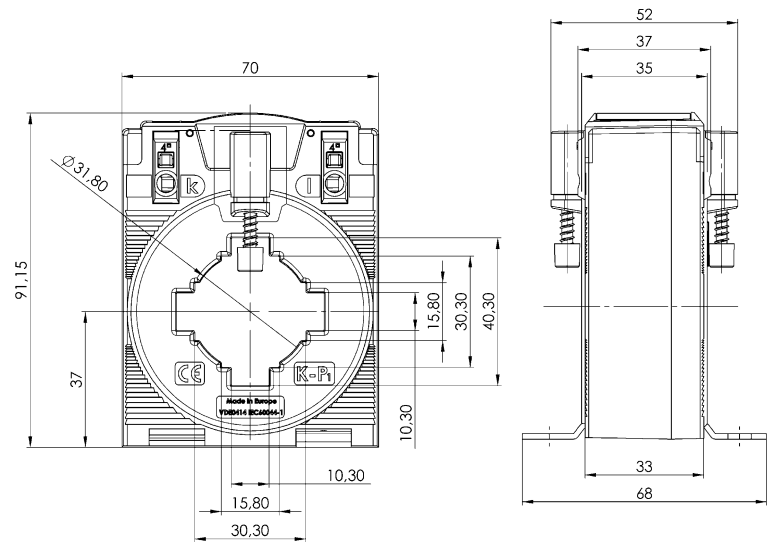

Dimensions:

- Bus bar 1: 40 x 10 mm
- Bus bar 2: 30 x 15 mm
- Circular conductor: 31.8 mm
- Installation width: 70 mm
- Installation height: 91.15 mm
- Overall installation depth: 52 mm

Technical data:

- Therm. nominal continuous current I_{cth} : $1.2 \times I_N$
- Therm. nominal short-time current I_{th} : $60 \times I_N$, 1 s
- Max. operating voltage U_m : 1.2 kV, U_{rms}
- Insulation test voltage: 6 kV, U_{rms} , 50 Hz, 1 min
- Lightning impulse voltage: 12 kV, 1.2/50 μ s**
- Nominal frequency: 50/60 Hz
- Technical standards applied: DIN EN 61869, Part 1 + 2
- Harmonic measurements with load 0.2 VA – Sr pf1
- Measuring accuracy up to 20 kHz: $\epsilon \leq 2\%$ | $\Delta\phi \leq 2^\circ$ @ **0.05–10 kHz**
 $\epsilon \leq 3\%$ | $\Delta\phi \leq 3^\circ$ @ **10–20 kHz**

Ordering table for XCTB 41.35 with secondary current 5 A

Secondary current		5 A				
Primary current [A]	Rated power [VA]	Accuracy class				
		1	0.5	0.5S	0.2	0.2S
		Order no.	Order no.	Order no.	Order no.	Order no.
125	2.5	51-0101				
150	2.5	51-0102				
200	1.5		51-0112	51-0126		
	2.5		51-0113			
	5	51-0103				
250	2.5		51-0114	51-0127		
	5	51-0104				
300	2.5		51-0115	51-0128		
	5	51-0105	51-0116			
400	5	51-0106	51-0117	51-0129		
500	2.5		51-0118	51-0130	51-0136	
	5	51-0107	51-0119	51-0131		
600	2.5		51-0120	51-0132	51-0137	51-0141
	5	51-0108	51-0121	51-0133	51-0138	
750	2.5		51-0122	51-0134	51-0139	51-0142
	5	51-0109	51-0123	51-0135	51-0140	51-0143
800	5	51-0110	51-0124			
1000	5	51-0111	51-0125			

Ordering table for XCTB 41.35 with secondary current 1 A

Secondary current		1 A				
Primary current [A]	Rated power [VA]	Accuracy class				
		1	0.5	0.5S	0.2	0.2S
		Order no.	Order no.	Order no.	Order no.	Order no.
75	1	51-2101				
80	1	51-2102				
100	1.25	51-2103				
125	2.5	51-2104				
150	2.5	51-2105				
200	1.5		51-2115	51-2129		
	2.5		51-2116			
	5	51-2106				
250	2.5		51-2117	51-2130		
	5	51-2107				
300	2.5		51-2118	51-2131		
	5	51-2108	51-2119			
400	5	51-2109	51-2120	51-2132		
500	2.5		51-2121	51-2133	51-2139	
	5	51-2110	51-2122	51-2134		
600	2.5		51-2123	51-2135	51-2140	
	5	51-2111	51-2124	51-2136	51-2141	
750	2.5		51-2125	51-2137	51-2142	
	5	51-2112	51-2126	51-2138		
800	5	51-2113	51-2127			
1000	5	51-2114	51-2128			

Accessories

Quick-fix (order no.: 55021)



Cover sealing (order no.: 59057)



Snap-on mount for installing the transformer on a 35 mm DIN rail (order no.: 55015)



XCTB 51.35

Plug-in current transformers

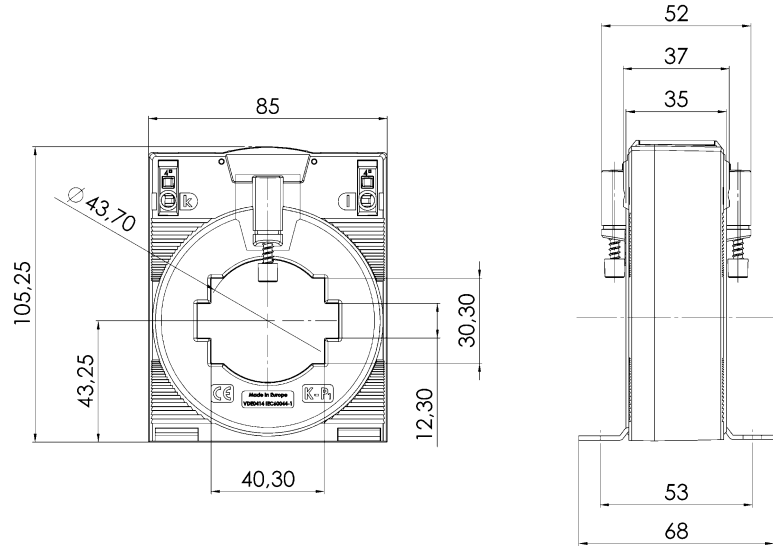

Dimensions:

- Bus bar 1: 50 x 12 mm
- Bus bar 2: 40 x 30 mm
- Circular conductor: 43.7 mm
- Installation width: 85 mm
- Installation height: 105.25 mm
- Overall installation depth: 52 mm

Technical data:

- Therm. nominal continuous current I_{cth} : $1.2 \times I_N$
- Therm. nominal short-time current I_{th} : $60 \times I_N$, 1 s
- Max. operating voltage U_m : 1.2 kV, U_{rms}
- Insulation test voltage: 6 kV, U_{rms} , 50 Hz, 1 min
- Lightning impulse voltage: 12 kV, 1.2/50 μ s**
- Nominal frequency: 50/60 Hz
- Technical standards applied: DIN EN 61869, Part 1 + 2
- Harmonic measurements with load 0.2 VA – Sr pf1
- Measuring accuracy up to 20 kHz: $\epsilon \leq 2\% \mid \Delta\phi \leq 2^\circ @ 0.05\text{--}10 \text{ kHz}$
 $\epsilon \leq 3\% \mid \Delta\phi \leq 3^\circ @ 10\text{--}20 \text{ kHz}$

Ordering table for XCTB 51.35 with secondary current 5 A

Secondary current		5 A				
Primary current [A]	Rated power [VA]	Accuracy class				
		1	0.5	0.5S	0.2	0.2S
		Order no.	Order no.	Order no.	Order no.	Order no.
100	1.25	51-0201				
	1.5		51-0215	51-0236		
125	1.5		51-0216	51-0237		
	2.5	51-0202				
150	2.5	51-0203	51-0217	51-0238		
200	1.5		51-0218	51-0239	51-0254	
	2.5		51-0219	51-0240		
	5	51-0204				
250	1.5		51-0220	51-0241	51-0255	51-0268
	2.5		51-0221	51-0242	51-0256	
	5	51-0205				
300	2.5		51-0222	51-0243	51-0257	51-0269
	5	51-0206	51-0223	51-0244	51-0258	
400	2.5		51-0224	51-0245	51-0259	51-0270
	5	51-0207	51-0225	51-0246	51-0260	
500	2.5		51-0226	51-0247	51-0261	51-0271
	5	51-0208	51-0227	51-0248	51-0262	51-0272
600	2.5		51-0228	51-0249	51-0263	51-0273
	5	51-0209	51-0229	51-0250	51-0264	51-0274
750	2.5		51-0230	51-0251	51-0265	51-0275
	5	51-0210	51-0231	51-0252	51-0266	51-0276
800	5	51-0211	51-0233			
1000	5	51-0212	51-0232	51-0253	51-0267	51-0277
1200	5	51-0213	51-0234			
1250	5	51-0214	51-0235			

Ordering table for XCTB 51.35 with secondary current 1 A

Secondary current		1 A				
Primary current [A]	Rated power [VA]	Accuracy class				
		1	0.5	0.5S	0.2	0.2S
		Order no.	Order no.	Order no.	Order no.	Order no.
100	1.25	51-2201				
	1.5		51-2215	51-2237		
125	1.5		51-2216	51-2238		
	2.5	51-2202				
150	2.5	51-2203	51-2217	51-2239		
200	1.5		51-2218	51-2240	51-2256	
	2.5		51-2219	51-2241	51-2257	
	5	51-2204				
250	1.5		51-2220	51-2242	51-2258	51-2270
	2.5		51-2221	51-2243	51-2259	
	5	51-2205	51-2222	51-2244		
300	2.5		51-2223	51-2245	51-2260	51-2271
	5		51-2224	51-2246	51-2261	51-2206
400	2.5		51-2225	51-2247	51-2262	
	5	51-2207	51-2226	51-2248	51-2272	
500	2.5		51-2227	51-2249	51-2263	51-2273
	5	51-2208	51-2228	51-2250	51-2264	51-2274
600	2.5		51-2229	51-2251	51-2265	51-2275
	5	51-2209	51-2230	51-2252	51-2266	
750	2.5		51-2231	51-2253	51-2267	51-2276
	5	51-2210	51-2232	51-2254	51-2268	
800	5	51-2211	51-2233			
1000	5	51-2212	51-2234	51-2255	51-2269	51-2277
1200	5	51-2213	51-2235			
1250	5	51-2214	51-2236			

Accessories

Quick-fix (order no.: 55021)



Cover sealing (order no.: 59058)



XCTB 61.35 Plug-in current transformers

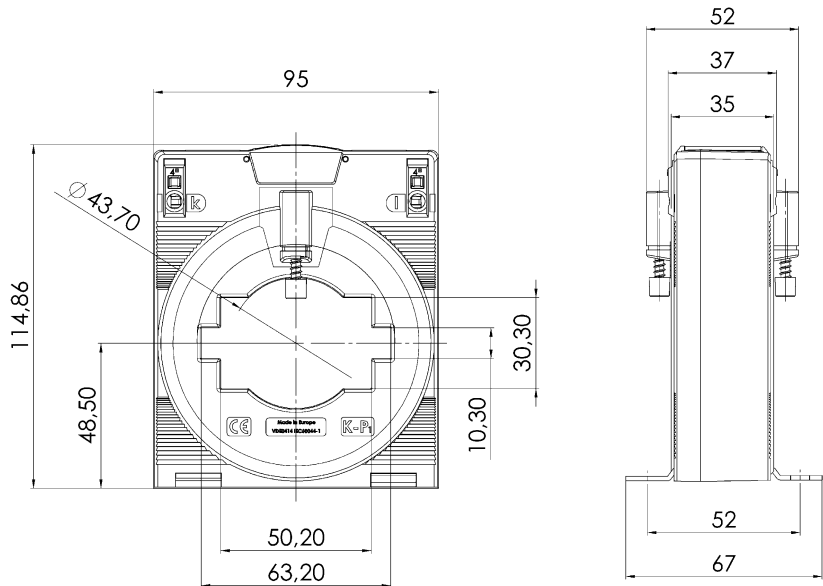

Dimensions:

- Bus bar 1: 63 x 10 mm
- Bus bar 2: 50 x 30 mm
- Circular conductor: 43.7 mm
- Installation width: 95 mm
- Installation height: 114.86 mm
- Overall installation depth: 52 mm

Technical data:

- Therm. nominal continuous current I_{cth} : $1.2 \times I_N$
- Therm. nominal short-time current I_{th} : $60 \times I_N$, 1 s
- Max. operating voltage U_m : 1.2 kV, U_{rms}
- Insulation test voltage: 6 kV, U_{rms} , 50 Hz, 1 min
- Lightning impulse voltage: 12 kV, 1.2/50 μ s**
- Nominal frequency: 50/60 Hz
- Technical standards applied: DIN EN 61869, Part 1 + 2
- Harmonic measurements with load 0.2 VA – Sr pf1
- Measuring accuracy up to 20 kHz: $\epsilon \leq 2\% \mid \Delta\phi \leq 2^\circ @ 0.05\text{--}10 \text{ kHz}$
 $\epsilon \leq 3\% \mid \Delta\phi \leq 3^\circ @ 10\text{--}20 \text{ kHz}$

Ordering table for XCTB 61.35 with secondary current 5 A

Secondary current		5 A				
Primary current [A]	Rated power [VA]	Accuracy class				
		1	0.5	0.5S	0.2	0.2S
		Order no.	Order no.	Order no.	Order no.	Order no.
200	1.5		51-0314	51-0334	51-0353	
	2.5	51-0301	51-0315	51-0335	51-0354	
250	1.5		51-0316	51-0336	51-0355	
	2.5		51-0317	51-0337	51-0356	
	5	51-0302	51-0318	51-0338		
300	2.5		51-0319	51-0339	51-0357	51-0368
	5	51-0303	51-0320	51-0340	51-0358	
400	2.5		51-0321	51-0341	51-0359	51-0369
	5	51-0304	51-0322	51-0342	51-0360	
500	2.5		51-0323	51-0343	51-0361	51-0370
	5	51-0305	51-0324	51-0344	51-0362	51-0371
600	2.5		51-0325	51-0345	51-0363	51-0372
	5	51-0306	51-0326	51-0346	51-0364	51-0373
750	5	51-0307	51-0327	51-0347	51-0365	51-0374
800	5	51-0308	51-0328	51-0348	51-0366	
1000	5	51-0309	51-0329	51-0349	51-0367	
1200	5	51-0310	51-0330	51-0350		
1250	5	51-0311	51-0331			
1500	5	51-0312	51-0332	51-0352		
1600	5	51-0313	51-0333			

Ordering table for XCTB 61.35 with secondary current 1 A

Secondary current		1 A				
Primary current [A]	Rated power [VA]	Accuracy class				
		1	0.5	0.5S	0.2	0.2S
		Order no.	Order no.	Order no.	Order no.	Order no.
200	1.5		51-2314	51-2334	51-2353	
	2.5	51-2301	51-2315	51-2335	51-2354	
250	1.5		51-2316	51-2336	51-2355	51-2371
	2.5		51-2317	51-2337	51-2356	
	5	51-2302	51-2318	51-2338		
300	2.5		51-2319	51-2339	51-2357	51-2372
	5	51-2303	51-2320	51-2340	51-2358	
400	2.5		51-2321	51-2341	51-2359	51-2373
	5	51-2304	51-2322	51-2342	51-2360	
500	2.5		51-2323	51-2343	51-2361	51-2374
	5	51-2305	51-2324	51-2344	51-2362	51-2375
600	2.5		51-2325	51-2345	51-2363	51-2376
	5	51-2306	51-2326	51-2346	51-2364	51-2377
750	5	51-2307	51-2327	51-2347	51-2365	51-2378
800	5	51-2308	51-2328	51-2348	51-2366	
1000	5	51-2309	51-2329	51-2349	51-2367	
1200	5	51-2310	51-2330	51-2350	51-2368	
1250	5	51-2311	51-2331	51-2351	51-2369	
1500	5	51-2312	51-2332	51-2352	51-2370	
1600	5	51-2313	51-2333			

Accessories

Quick-fix (order no.: 55021)



Cover sealing (order no.: 59059)



XCTB 81.35 Plug-in current transformers

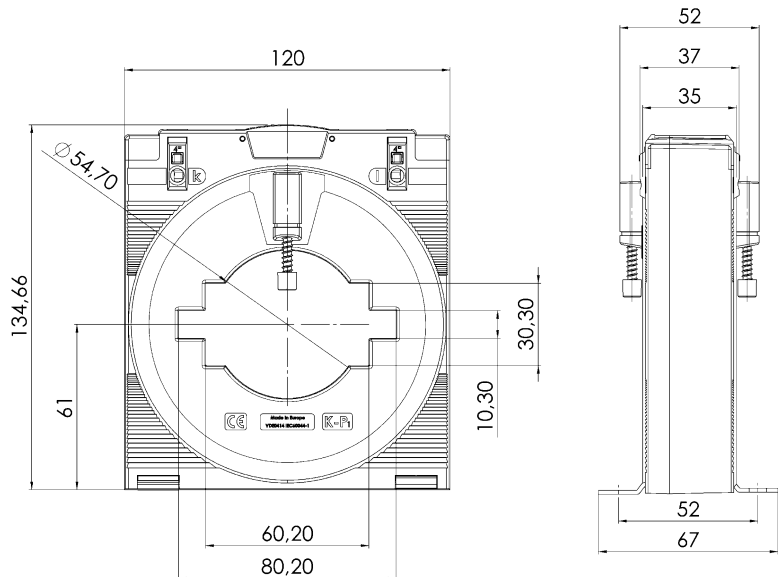

Dimensions:

Bus bar 1: 80 x 10 mm
 Bus bar 2: 60 x 30 mm
 Circular conductor: 54.7 mm
 Installation width: 120 mm
 Installation height: 134.66 mm
 Overall installation depth: 52 mm

Technical data:

Therm. nominal continuous current I_{cth} : $1.2 \times I_N$
 Therm. nominal short-time current I_{th} : $60 \times I_N$, 1 s (max. 100 kA)
 Max. operating voltage U_m : 1.2 kV, U_{rms}
 Insulation test voltage: 6 kV, U_{rms} , 50 Hz, 1 min
Lightning impulse voltage: 12 kV, 1.2/50 μ s
 Nominal frequency: 50/60 Hz
 Technical standards applied: DIN EN 61869, Part 1 + 2
 Harmonic measurements with load 0.2 VA – Sr pf1
 Measuring accuracy up to 20 kHz: $\epsilon \leq 2\% \mid \Delta\phi \leq 2^\circ @ 0.05\text{--}10 \text{ kHz}$
 $\epsilon \leq 3\% \mid \Delta\phi \leq 3^\circ @ 10\text{--}20 \text{ kHz}$

Ordering table for XCTB 81.35 with secondary current 5 A

Secondary current		5 A				
Primary current [A]	Rated power [VA]	Accuracy class				
		1	0.5	0.5S	0.2	0.2S
		Order no.	Order no.	Order no.	Order no.	Order no.
400	2.5		51-0411	51-0426	51-0440	
	5	51-0401				
500	2.5		51-0412	51-0427	51-0441	51-0454
	5	51-0402	51-0413			
600	2.5		51-0414	51-0428	51-0442	51-0455
	5	51-0403	51-0415	51-0429	51-0443	51-0456
750	2.5		51-0416	51-0430	51-0444	51-0457
	5	51-0404	51-0417	51-0431	51-0445	51-0458
800	2.5		51-0418	51-0432	51-0446	51-0459
	5	51-0405	51-0419	51-0433	51-0447	51-0460
1000	5	51-0406	51-0420	51-0434	51-0448	51-0461
1200	5	51-0407	51-0421	51-0435	51-0449	51-0462
1250	5	51-0408	51-0422	51-0436	51-0450	51-0463
1500	5	51-0409	51-0423	51-0437	51-0451	51-0464
1600	5	51-0410	51-0424	51-0438	51-0452	51-0465
2000	5		51-0425	51-0439	51-0453	51-0466

Ordering table for XCTB 81.35 with secondary current 1 A

Secondary current		1 A				
Primary current [A]	Rated power [VA]	Accuracy class				
		1	0.5	0.5S	0.2	0.2S
		Order no.	Order no.	Order no.	Order no.	Order no.
400	2.5		51-2411	51-2426	51-2441	
	5	51-2401				
500	2.5		51-2412	51-2427	51-2442	51-2455
	5	51-2402	51-2413	51-2428		
600	2.5		51-2414	51-2429	51-2443	51-2456
	5	51-2403	51-2415	51-2430	51-2444	51-2457
750	2.5		51-2416	51-2431	51-2445	51-2458
	5	51-2404	51-2417	51-2432	51-2446	51-2459
800	2.5		51-2418	51-2433	51-2447	51-2460
	5	51-2405	51-2419	51-2434	51-2448	51-2461
1000	5	51-2406	51-2420	51-2435	51-2449	51-2462
1200	5	51-2407	51-2421	51-2436	51-2450	51-2463
1250	5	51-2408	51-2422	51-2437	51-2451	51-2464
1500	5	51-2409	51-2423	51-2438	51-2452	51-2465
1600	5	51-2410	51-2424	51-2439	51-2453	51-2466
2000	5		51-2425	51-2440	51-2454	51-2467

Accessories

Quick-fix (order no.: 55021)



Cover sealing (order no.: 59059)



XCTB 101.35

Plug-in current transformers

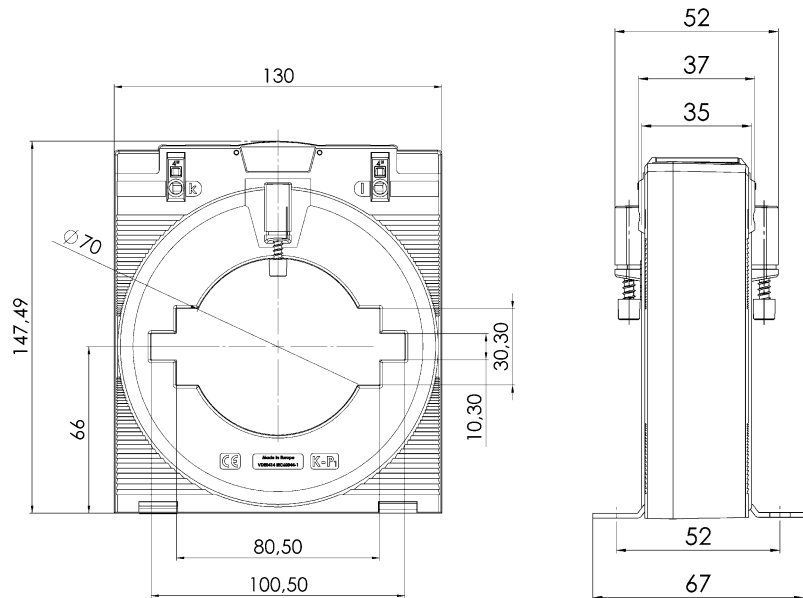

Dimensions:

Bus bar 1: 100 x 10 mm
 Bus bar 2: 80 x 30 mm
 Circular conductor: 70 mm
 Installation width: 130 mm
 Installation height: 147.49 mm
 Overall installation depth: 52 mm

Technical data:

Therm. nominal continuous current I_{cth} : $1.2 \times I_N$
 Therm. nominal short-time current I_{th} : $60 \times I_N$, 1 s (max. 100 kA)
 Max. operating voltage U_m : 1.2 kV, U_{rms}
 Insulation test voltage: 6 kV, U_{rms} , 50 Hz, 1 min
Lightning impulse voltage: 12 kV, 1.2/50 μ s
 Nominal frequency: 50/60 Hz
 Technical standards applied: DIN EN 61869, Part 1 + 2
 Harmonic measurements with load 0.2 VA – Sr pf1
 Measuring accuracy up to 20 kHz: $\epsilon \leq 2\%$ | $\Delta\phi \leq 2^\circ$ @ 0.05–10 kHz
 $\epsilon \leq 3\%$ | $\Delta\phi \leq 3^\circ$ @ 10–20 kHz

Ordering table for XCTB 101.35 with secondary current 5 A

Secondary current		5 A				
Primary current [A]	Rated power [VA]	Accuracy class				
		1	0.5	0.5S	0.2	0.2S
		Order no.	Order no.	Order no.	Order no.	Order no.
400	2.5		51-0508			
	5	51-0501				
500	2.5		51-0509			
	5	51-0502	51-0510			
600	2.5		51-0511	51-0523		
	5		51-0512			
750	2.5		51-0513	51-0524		
	5	51-0503	51-0514	51-0525		
800	2.5		51-0515	51-0526		
	5	51-0504	51-0516	51-0527		
1000	5	51-0505	51-0517	51-0528	51-0534	
1200	5	51-0506	51-0518	51-0529	51-0535	51-0540
1250	5	51-0507	51-0519	51-0530	51-0536	51-0541
1500	5		51-0520	51-0531	51-0537	51-0542
1600	5		51-0521	51-0532	51-0538	51-0543
2000	5		51-0522	51-0533	51-0539	51-0544

Ordering table for XCTB 101.35 with secondary current 1 A

Secondary current		1 A				
Primary current [A]	Rated power [VA]	Accuracy class				
		1	0.5	0.5S	0.2	0.2S
		Order no.	Order no.	Order no.	Order no.	Order no.
400	2.5		51-2508			
	5	51-2501				
500	2.5		51-2509	51-2523		
	5	51-2502	51-2510			
600	2.5		51-2511	51-2524		
	5		51-2512	51-2525		
750	2.5		51-2513	51-2526		
	5	51-2503	51-2514	51-2527		
800	2.5		51-2515	51-2528	51-2536	
	5	51-2504	51-2516	51-2529		
1000	5	51-2505	51-2517	51-2530	51-2537	51-2543
1200	5	51-2506	51-2518	51-2531	51-2538	51-2544
1250	5	51-2507	51-2519	51-2532	51-2539	51-2545
1500	5		51-2520	51-2533	51-2540	51-2546
1600	5		51-2521	51-2534	51-2541	51-2547
2000	5		51-2522	51-2535	51-2542	51-2548

Accessories

Quick-fix (order no.: 55021)



Cover sealing (order no.: 59059)





- Current transformers for industry
- Current transformers for tariffs
- Accessories for current transformers
- Medium-voltage transformers
- Bus bar insulators / -supports
- Shunts
- Voltage transformers
- All current sensors
- Measuring transducers
- Energy meters with or without MID approval
- Accessories for energy meters
- Panel board heaters, filter fans, roof fans and control units



www.mbs-ag.com



MBS AG
Eisbachstraße 51 • 74429 Sulzbach-Laufen • Germany
Telefon: +49 7976 9851-0 • Telefax: +49 7976 9851-90
info@mbs-ag.com • www.mbs-ag.com